

### Converting to Chaise Lounge position

Lift the leg rest cushion and push the support leg back to the bottom of the cushion, then carefully place the cushion on the floor.

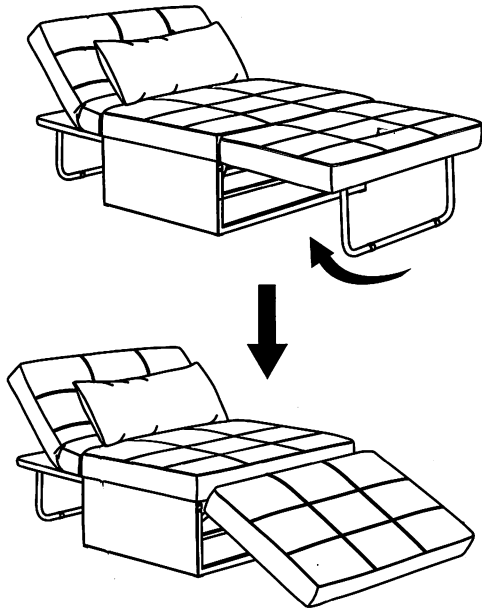

### Ottoman

When using as an ottoman, fix the skirt covers by using the magnets.

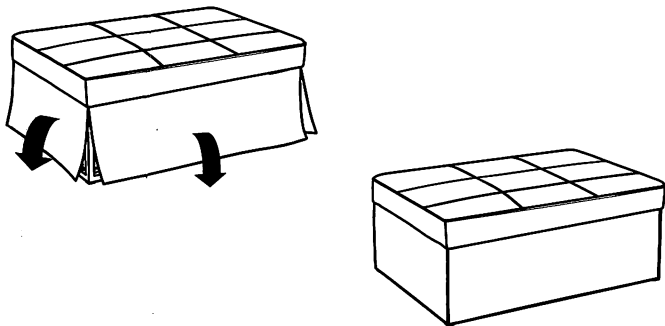

# AINFOXC

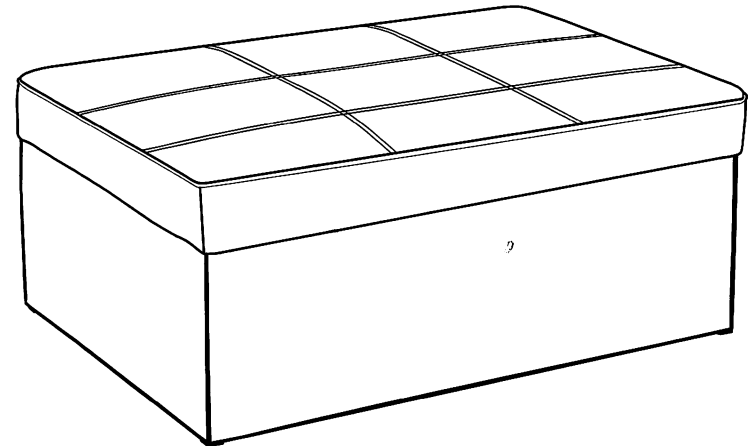

## Ottoman Folding Bed

---

ASSEMBLY INSTRUCTIONS

## PARTS AND HARDWARE

Avoid using sharp objects such as a knife to cut open packing as you may accidentally damage the upholstery.

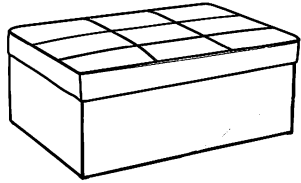

Ottoman Unit  
1x



Pillow  
1x

THIS UNIT DOES NOT REQUIRE ANY ASSEMBLY

## OPERATING YOUR UNIT

### Converting to Chair

Lift up all four sides of the ottoman skirting. Standing at the side of the unit, lift the top seat cushion completely upright, fix the two longest skirt covers to the magnet, then lift the support leg of the headrest (second cushion) and flip it over. Next, carefully set down the top upright seat cushion, fix the two short skirt covers to the base frame by magnet and then convert the backrest as desired with the sound of each click. Finally place the pillow as desired.

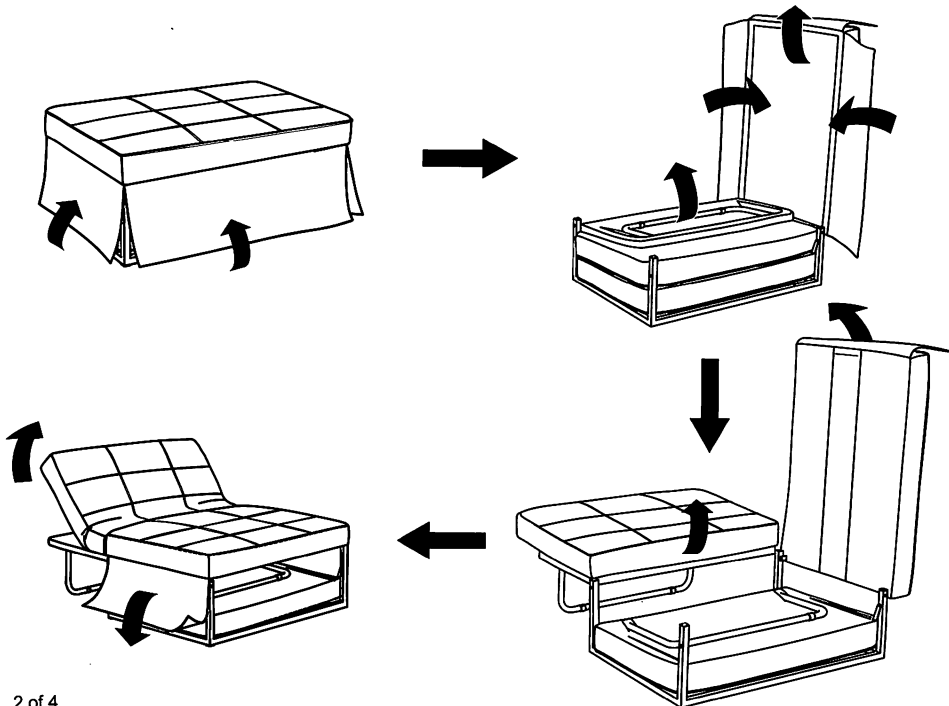

### Converting to Bed

Lift the backrest all the way upwards until the last click is heard (which unlocks the mechanism) and carefully return to a flat position. Next, open the two shortest skirt covers and lift the chair cushion upwards until it stops. Then lift the bottom cushion by the support leg to flip over the cushion and rest the support leg on the floor. Fix the two short skirt covers the base frame by magnet. Finally, place the pillow as desired.

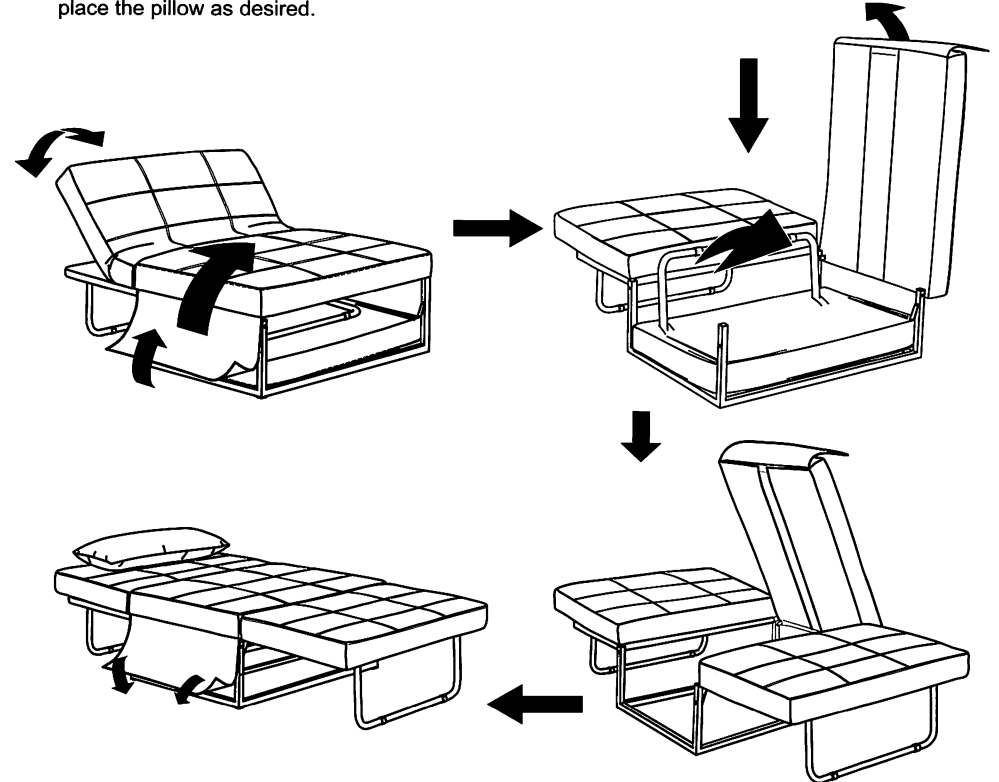

### Converting to Chaise

Standing at the side of the unit, lift the back-rest to the desired position and secure it in place by releasing to the sound of a click. Place the pillow as desired.

